

Installation and Calibration Instructions

SW-200B Speed Switch

- 1. Installation:** Mount the SW-200B to a secure bracket off the engine. If on-engine mounting is necessary, shock mounts are recommended. Wire according to connection diagram on reverse. Shielded cable is recommended. Shield should be brought to ground directly. The SW-200B will work with most magnetic pickups provided the signal amplitude is greater than 50 mVrms and less than 70 Vrms. Mount pickup according to manufacturer's instructions.
- 2. Calibration:** Determine the setpoint frequencies from an RPM value using the following formula:

$$\text{Frequency} = \frac{\text{RPM} \times \text{No. of Teeth (Holes)}}{60}$$

- A. Verify the current calibration:** use a signal generator. Connect it to the SW-200B magnetic pickup input.
- B. Confirm the DIP switches are properly set for the frequency range and overspeed relay logic desired.** (See chart below.)
- C. Set the signal generator output to at least 10% below the lowest setpoint.** Slowly increase the frequency. Using an ohmmeter across the relay contacts, determine the frequency at which each relay changes state.
 - a. Change a setpoint:** remove the appropriate access hole screw to reach the setpoint's relay adjustment trim pot.
 - Set the signal generator to the frequency at which the relay should change state. Connect it to the SW-200B magnetic pickup input.
 - Using a small, flat screwdriver, adjust the trim pot for the appropriate relay until the relay changes state.
 - Decrease the frequency, then slowly increase it to verify that the relay trips at the appropriate point. *Replace the access hole screw.*

DIP SWITCH SETTINGS

Switches 1 & 2 set the full-scale frequency range				Switches 3 & 4 set the overspeed relay logic			
DIP SW 1	DIP SW 2		Full-Scale Range	DIP SW 3	DIP SW 4		Relay Logic
OFF	OFF	=	0 – 11,200 Hz	ON	N/A	=	Energizes Above Setpoint
OFF	ON	=	0 – 5,000 Hz	OFF	N/A	=	De-Energize Above Setpoint
ON	ON	=	0 – 1,000 Hz	N/A	ON	=	Latches
				N/A	OFF	=	Does not Latch

SW-200B is a trademark of Dynalco Controls

DYNALCO CONTROLS RESERVES THE RIGHT TO CHANGE THESE SPECIFICATIONS WITHOUT NOTICE.

Azonix-Dynalco, 3690 N.W. 53rd Street, Fort Lauderdale, FL 33309 U.S.A.

☎(954) 739-4300 • Fax (954) 484-3376 • www.dynalco.com • mailbox@dynalco.com

CONNECTION DRAWINGS

SW-200B

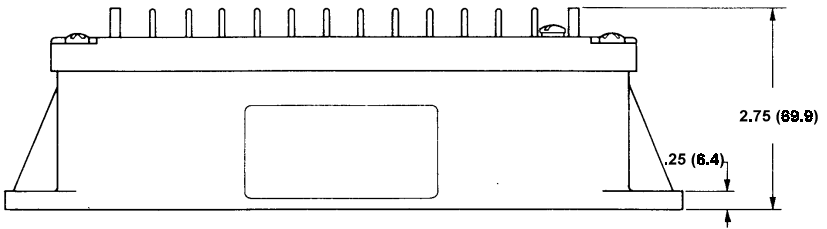
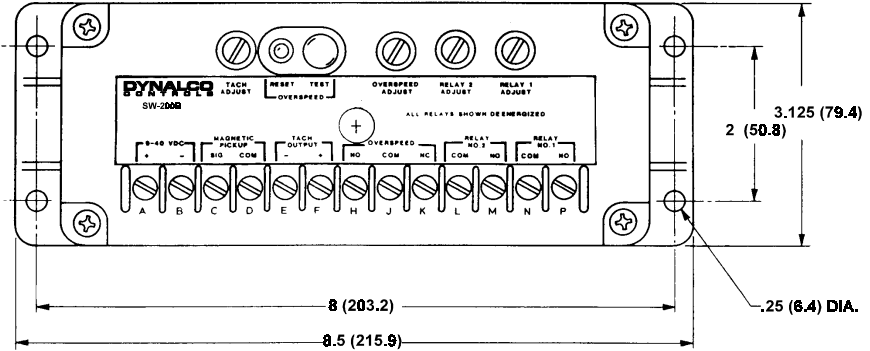

Dimensions In Inches (millimeters)

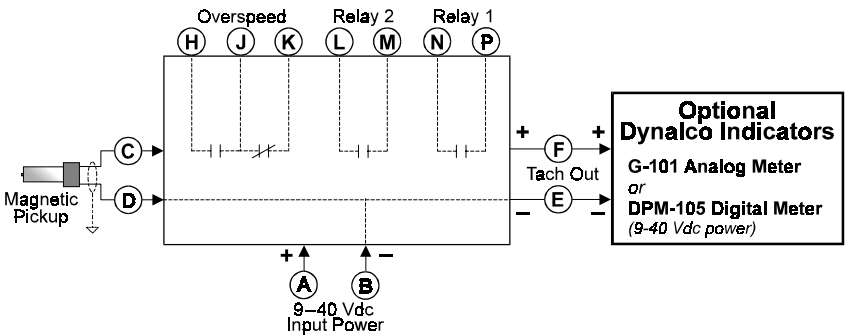

SW-200B shown with power OFF, no input, all relays deenergized.
 Note label on SW-200B in Overview, above.
 Other setups are available.